

Carl Frael
Gentle Electric
119 BRAINERD RD. #15
ALLSTON, MA 02134
(617) 731-4844

NOTES ON ARIES MODIFICATION
FOR MICHAEL GILBERT, JO#1253
6 MARCH 1976

NEW PIN ASSIGNMENTS FOR OCTAL ACCESSORY JACK

<u>PIN #</u>	<u>OLD ASSIGNMENT</u>	<u>NEW ASSIGNMENT</u>	<u>CABLE WIRE COLOR</u>
1	} +15V	+15V	RED
2		VOICE	BLACK PAIR
3	} -15V	-15V	YELLOW
4		2ND VOICE	BLACK PAIR
5	} +5V	+5V	BLUE
6		GATE	BLACK PAIR
7	} GROUND	GROUND	BROWN
8		TRIGGER	BLACK PAIR

NOTE: BOTH OCTAL JACKS ON BACK OF MAIN CABINET HAVE THIS NEW ASSIGNMENT

TRIM PROCEDURE FOR KEYBOARD INTERFACE

THIS ASSUMES THAT THE VCO'S ARE TRIMMED REASONABLY CLOSE TO 1V/OCTAVE AND THAT THEY TRACK EACH OTHER VERY CLOSELY.

THE KEYBOARD-TO-VCO TRIMMING SHOULD ^{ALWAYS} BE DONE THROUGH THE SAME CONTROL INPUTS ON THE VCO'S, AND PREFERABLY NOT THROUGH ATTENUATABLE INPUTS. INPUTS 3 ARE RECOMMENDED.

- connect voice to VCO1, input 3. (KEYBOARD TUNING POT CENTERED) Listen to narrow pulse waves of both VCO'S, TUNED TO EXACT UNISON (AT ABOUT 60 HZ) WHEN LOWEST KEY IS DEPRESSED.
- DEPRESS KEYS IN ASCENDING OCTAVES, ~~TUNING~~ ADJUSTING "VOICE TRIM" ~~MANUAL~~ ON THE KEYBOARD TO CORRECT INTONATION. AFTER EACH ADJUSTMENT OF "VOICE", RETUNE THE OSCILLATORS WITH LOWEST KEY DEPRESSED.
- DISCONNECT VOICE FROM VCO1. CONNECT AUX VOICE TO VCO INPUTS. DEPRESS LOWEST KEY AND TUNE OSCILLATORS TO UNISON. ALWAYS KEEPING LOWEST KEY DEPRESSED, PLAY ALSO HIGHER OCTAVES. IF THE HIGHER OCTAVE IS FLAT, ADJUST "AUX TRIM" CLOCKWISE (PITCH WILL FLATTEN EVEN MORE). IF SHARP, ADJUST counter-clockwise. AFTER EACH ADJUSTMENT, DEPRESS ONLY THE BOTTOM KEY AND RETUNE OSCILLATORS TO UNISON.

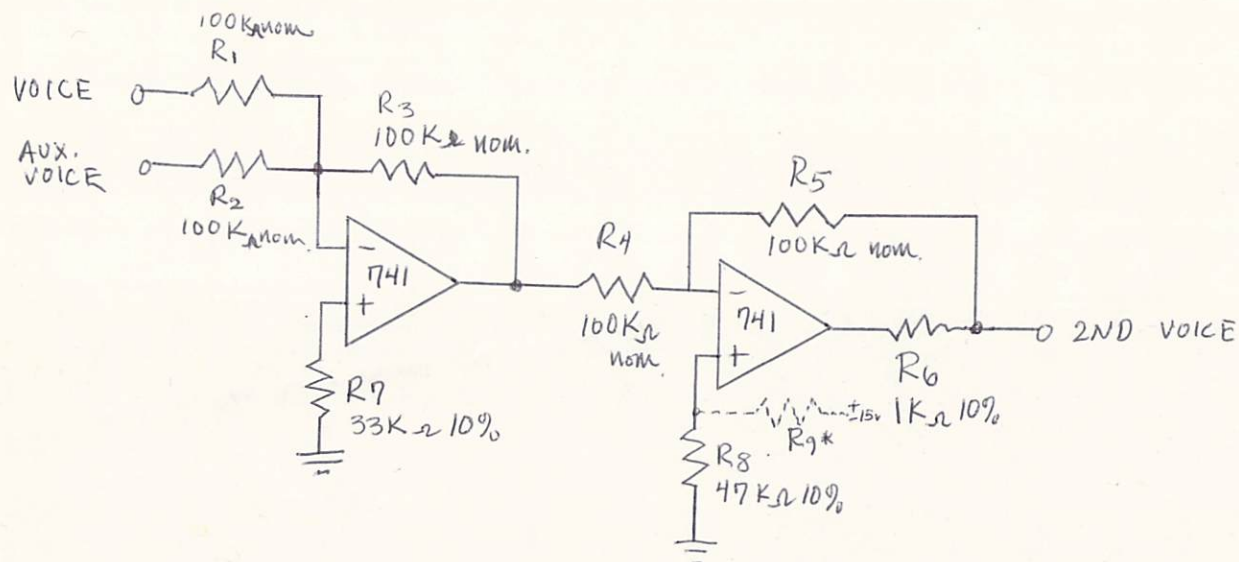

COMPONENT LAYOUT:

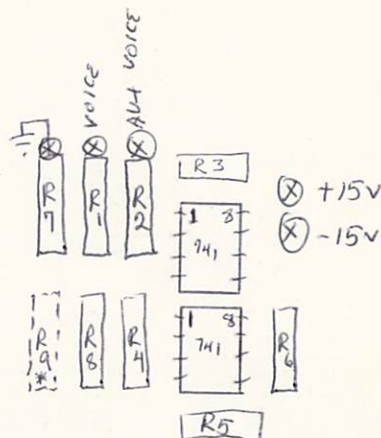

$$R_1 = R_2 = R_3 \pm 0.1\%$$

$$R_4 = R_5 \pm 0.1\%$$

* R₉ to be selected and connected to +0A - 15V for offset null after voice and aux. voice are trimmed

Carl Travel
Gentle Electric
119 DRAINERD RD. #15
ALLSTON, MA 02134
(617) 731-4844

VOICE ADDER
MODIFICATION TO ARIES AR313
for MICHAEL GILBERT, J.O.#1253
6 MARCH 1976